

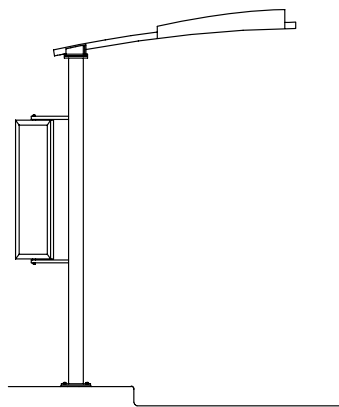

Atlanta, like any fast-paced city, has motorists that are always on the go and it is here that the drive-thru plays an essential role in everyday life. The Atlanta series of drive thru products offers easy access, informative signage, and lighted coverage so that your patrons are protected from the elements. All these products are engineered with tops that will rotate on impact from oversized vehicles. **Made in the U.S.A.**

CLEARANCE BAR



OPTIONAL SIGN BOX
12" x 44" VERTICAL

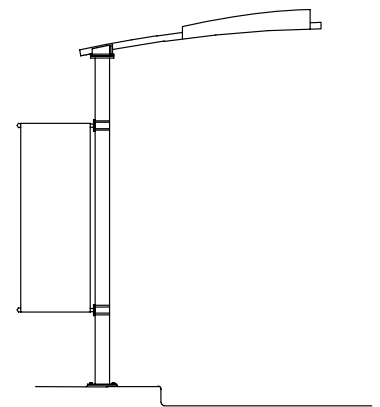

OPTIONAL TWO POLE
BANNER KIT



GUARDIAN SPEAKER COVER



STANDARD SPECIFICATIONS

- Post: 5" square steel. Black - Standard
- Canopy: 100% aluminum construction and will rotate upon impact
- Frame: tubing and plate 6063-T6
- Top cladding: .063" aluminum sheet 3003 series aluminum

OPTIONAL UPGRADES:

- CNC lifescapes, wood or composite accents
- Integrated LED lighting

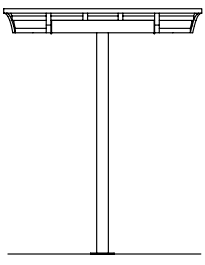

BASIC UNIT

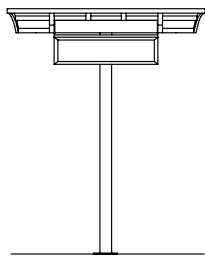

**STANDARD LIGHT BOX
12" x 44" HORIZONTAL**

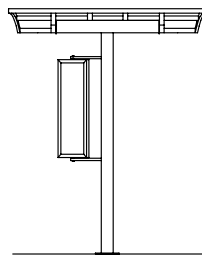

**STANDARD LIGHT BOX
12" x 44" VERTICAL**

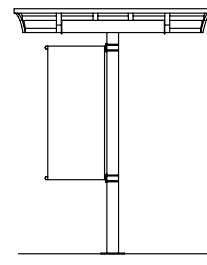

**TWO POLE BANNER KIT
BANNER NOT INCLUDED**