

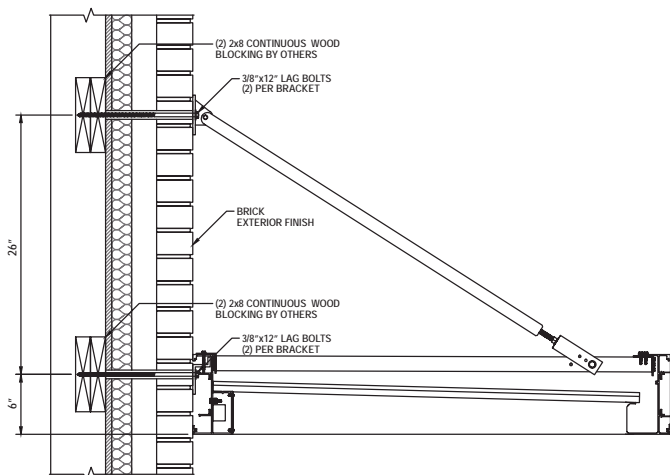

Seattle canopies are a unique system with innovative flexibility to provide rain protection. These canopies can be built with a front gutter and scuppers, or with a back gutter and downspouts to drain water. This powder coated, all-aluminum constructed canopy is easily installed and can be field fitted if necessary. Seattle canopies are also available with different face options and with integrated LED lighting for visual and functional effects. **Made in the U.S.A.**

#### BLOCKING EXAMPLES



BRICK WITH INSULATION OVER WOOD BLOCKING

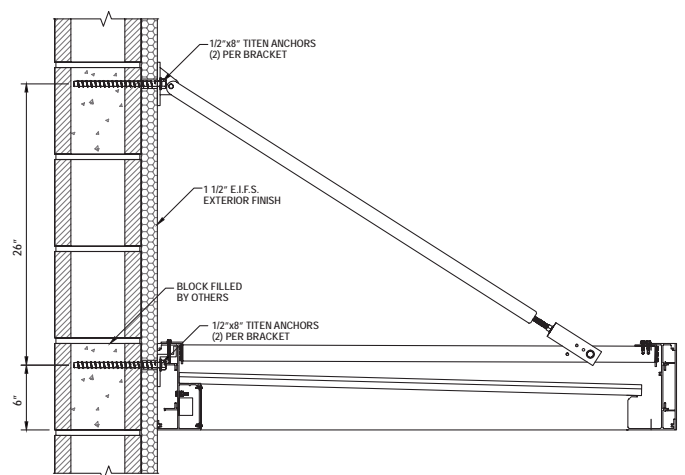

E.F.I.S. OVER CMU BLOCK WALL

### STANDARD SIZES

- Projection: up to 6'
- Frame Width: 48" - 176"
- Tie-Back Spacing: 88"
- Tie-Back Height: Flexible
- Tie-Back Rod:  $\varnothing$  1 1/4"
- Upper Clevis Bracket: 8" Wide

### CUSTOM SIZES

Projections that are greater than 6' are available, but will require additional engineering and fall outside our standard pricing models.

### HIGH WIND/SNOW LOAD

- Tie-Back Rod:  $\varnothing$  1 1/2"
- Upper Clevis Bracket: 10" Wide

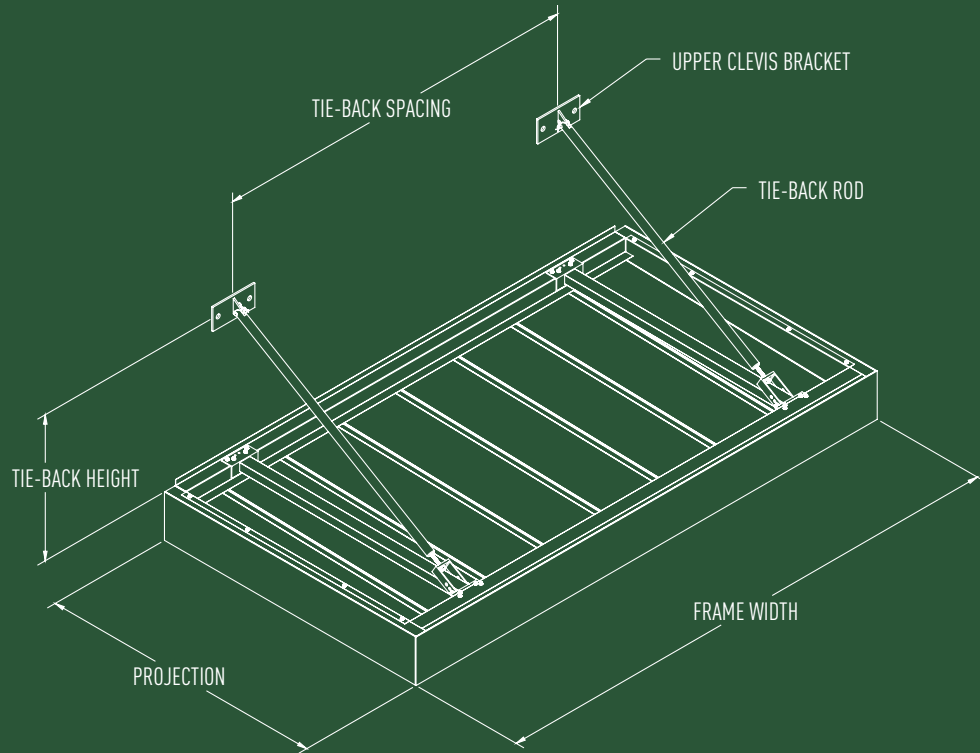

### CROSS SECTION

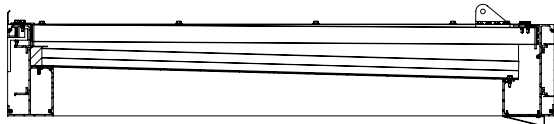

Gutter Forward With Scuppers

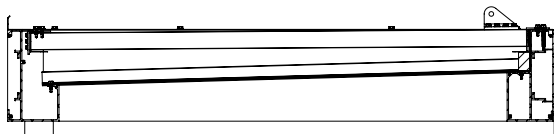

Gutter Back With Downspout

### FACE OPTIONS

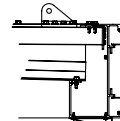

8" Flat (Standard)

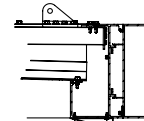

8" Open

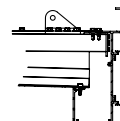

10" Flat

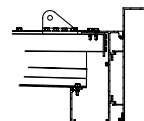

10" Open

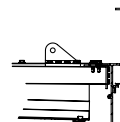

12" Flat

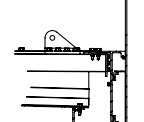

12" Open

Custom faces available upon request.

### LED LIGHTING

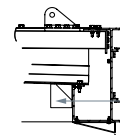

LED Module